



**OM PAK 35 – 150 W**  
Digital ignitor with timer

**Product description**

- Series OM choke
- Also suitable for high ambient temperatures up to 65 °C
- Rapid lamp starting and restarting thanks to integrated digital superimposed-pulse ignitor ZRM 2.5 ES/CT
- Automatic shutdown for a faulty lamp
- Temperature-protected
- Low-loss
- With F label for mounting on normally flammable materials
- Simple connection of all cables in a generously sized connection compartment; no tools required

→ For product data sheet go to [www.tridonic.com](http://www.tridonic.com), or available on request

**Technical data**

Ignitor	ZRM 2,5-ES/CT
Max. cable length to lamp (75 pF/m)	1.5 m



Product matrix, page 150

Lamp matrix, page 152

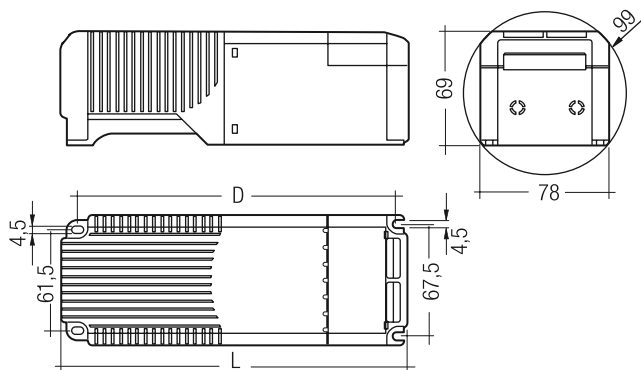

**Ordering data**

Weight	Packaging, cardboard	Packaging, pallet	Type	Article number
1.4 kg	1 pieces	135 pieces	<b>OM PAK 35 M B133</b> 230/240V 50Hz	<b>20889876</b>
1.8 kg	1 pieces	135 pieces	<b>OM PAK 70 M B133</b> 230/240V 50Hz	<b>22115608</b>
3.0 kg	1 pieces	108 pieces	<b>OM PAK 150 M B133</b> 230/240V 50Hz	<b>22115645</b>

**Specific technical data**

Type	Lamp wattage	Lamp type	Voltage	Mains frequency	Length L	Hole spacing D	Ambient temperature $t_a$	Power consumption	Mains current	$\lambda$
<b>OM PAK 35 M B133</b>	35 W	HI	230 / 240 V	50 Hz	210 mm	193.5 mm	65 °C	8.6 W	0.22 A	0.95
<b>OM PAK 70 M B133</b>	70 W	HI	230 / 240 V	50 Hz	210 mm	193.5 mm	55 °C	15.7 W	0.43 A	0.95
<b>OM PAK 150 M B133</b>	150 W	HS / HI	230 / 240 V	50 Hz	260 mm	243.5 mm	50 °C	24.0 W	0.76 A	