



Module EM-ER 004

EM-LED light sources

Product description

- LED emergency lighting module
- Escape route emergency lighting: illuminance E = 1.0 lux (as per EN 1838)
- Compatible with EM powerLED 1 W

Properties

- High-power LED in chip-on-board technology (COB)
- Long life thanks to integrated heat removal
- Optimised system efficacy with specific beam characteristic
- Integrated bi-colour status LED
- Reverse polarity protection
- Small dimensions
- Different installation options
- Connection: Cable 300 mm



Standards, page 2

Colour temperatures and tolerances, page 3

Wiring diagrams and installation examples, page 3

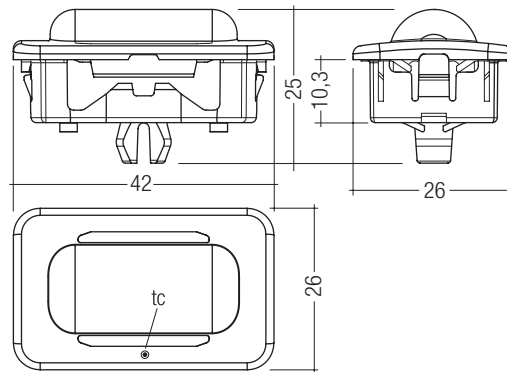

Technical data

Colour rendering index CRI	> 70
Ambient temperature range	-20 ... +50 °C
tp rated	45 °C
tc ^②	up to 85 °C
Max. DC forward current	700 mA
Max. permissible LF current ripple	960 mA
Max. permissible peak current	1,920 mA / max. 10 ms
Max. permissible output voltage of LED Driver	50 V
Insulation test voltage	11 kV

Ordering data

Type	Article number	Colour ^⑥	Colour temperature	Packaging, carton	Weight per pc.
EM-ER 004	89601889	Daylight white	6,500 K	10 pc(s).	0.016 kg

Specific technical data

Type	Typ. luminous flux ^④ \varnothing	Min. luminous flux ^④ \varnothing	Max. current ^③	Power ^⑤ \varnothing
EM-ER 004	110 lm	95 lm	350 mA	1 W

^① Data for operation with 350 mA.

^② If the max. temperature limits are exceeded, the life of the module will be reduced or the module may be damaged.

The temperature of the LED module at the tc-point is to be measured in the thermally stable state. For tc-point see the above diagram.

^③ Exceeding the max. operating current leads to an overload on the LED module. This may in turn result in a significant reduction in life-time or even destruction of the LED module.

^④ Tolerance range for optical data: ± 10 %.

^⑤ Tolerance range for electrical data: ± 5 %.

^⑥ Colour temperature and colour rendering index CRI according to CIE 1931.

^⑦ All values at tp = 45 °C.

Standards

- EN 62031
- EN 62471

Glow-wire test

according to EN 62031 with increased temperature of 850 °C passed.

Optical properties

Max. spacing for >1.0 lux for maintained mode ①

Height	Centre to end ②		Centre to centre ③	
	Transversal	Axial	Transversal	Axial
2.5 m	1.30 m	3.9 m	2.9 m	8.8 m
3.0 m	1.45 m	4.3 m	3.2 m	10.0 m
4.0 m	1.80 m	5.0 m	4.0 m	12.0 m
5.0 m	2.00 m	5.4 m	4.5 m	13.4 m

all values at tc = 45 °C

1 Maintainance factor = 0.8

Photometric data available on request

- 2 Distance between module and wall
- 3 Distance between two modules

tc point, ambient temperature and life-time

The temperature at tc reference point is crucial for the light output and life-time of a LED product.

Compliance with the maximum permissible reference temperature at the tc point must be checked under operating conditions in a thermally stable state. The maximum value must be determined under worst-case conditions for the relevant application.

Life-time declarations are informative and represent no warranty claim.

Storage and humidity

storage temperature	-30...+80 °C
---------------------	--------------

Operation only in non condensing environment.

Humidity during processing of the module should be between 30 to 70 %.

Mounting

Surface mounting:

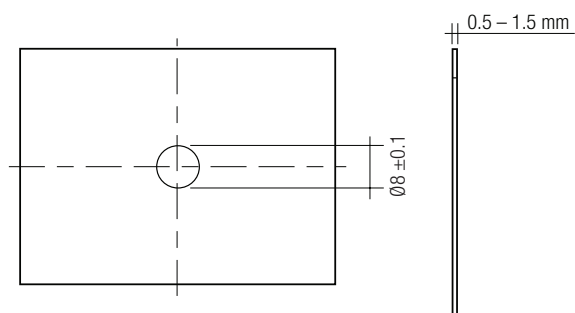

Recessed mounting:

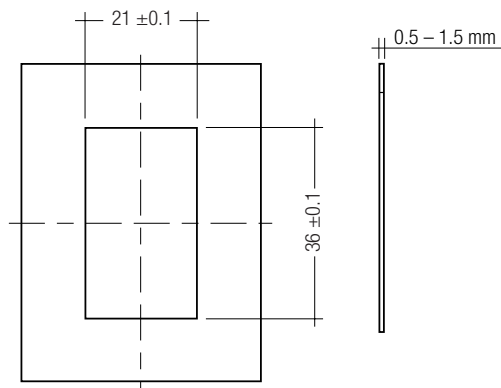

Light distribution

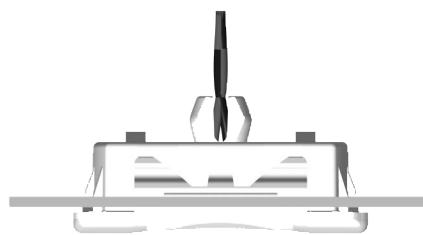
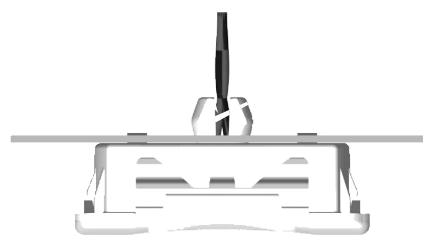
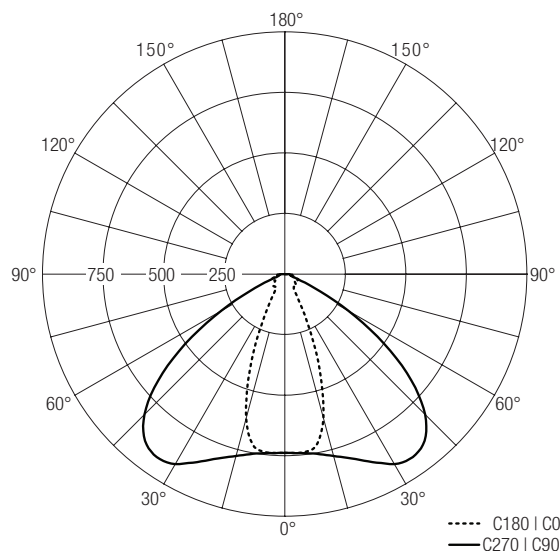

Electrical supply/choice of converter

EM-ER 004 modules from Tridonic are not protected against overvoltages, overcurrents, overloads or short-circuit currents. Safe and reliable operation can only be guaranteed in conjunction with a converter which complies with the relevant standards. The use of EM powerLED converters from Tridonic in combination with EM-ER 004 modules guarantees the necessary protection for safe and reliable operation.

If a converter other than Tridonic EM powerLED converter is used, it must provide the following protection:

- SELV
- Short-circuit protection
- Overload protection
- Overtemperature protection

The EM-ER 004 module must be supplied by a constant current converter. Operation with a constant voltage converter will lead to an irreversible damage of the module. The EM-ER 004 modules is protected against reversed polarity.



Chemical substance may harm the LED module. Chemical reactions could lead to colour shift, reduced luminous flux or a total failure of the module caused by corrosion of electrical connections.

Materials which are used in LED applications (e.g. sealings, adhesives) must not produce dissolver gas. They must not be condensation curing based, acetate curing based or contain sulfur, chlorine or phthalate.

Avoid corrosive atmosphere during usage and storage.



EOS/ESD safety guidelines

The device / module contains components that are sensitive to electrostatic discharge and may only be installed in the factory and on site if appropriate
EOS/ESD protection measures have been taken. No special measures need be taken for devices/modules with enclosed casings (contact with the pc board not possible), just normal installation practice. Please note the requirements set out in the document EOS / ESD guidelines (Guideline_EOS_ESD.pdf) at:
<http://www.tridonic.com/esd-protection>

Coordinates and tolerances according to CIE 1964

The specified colour coordinates are measured by a current impulse of 350 mA and a duration of 200 ms.

The ambient temperature of the measurement is $t_a = 25^\circ\text{C}$.

The measurement tolerance of the colour coordinates are ± 0.01 .

CIE coordinates:

Daylight white

	x0	y0
Centre	0.3200	0.3270

MacAdam ellipse: 5SDCM

Wiring

Cable: AWG24; length 300 mm

Colour	red	black	orange	pink
Function	+	-	Status A	Status K

Notes

The wiring acc. to the information above is valid for the usage in conjunction with EM powerLED ST and EM powerLED PRO.

When the EM-ER 004 is used with the EM powerLED BASIC the polarity of the indicator LED has to be changed. Connect the orange lead to the terminal "P" and the pink lead to the terminal "O".

When two EM-ER module are used with an EM powerLED 2W converter module only one indicator LED can be connected to the driver.

When the EM-ER is used in mains operation a separate indication LED must be used.

Note:

The indication LED is part of the EM-ER module.

Wiring example

