

EM converterLED ST 200 V

SELFTEST series

Product description

- Emergency lighting LED Driver with self-test function
- For LED modules with a forward voltage of 50 – 200 V
- Low profile casing (21 x 30 mm cross-section)
- 5-year guarantee

Properties

- Non maintained operation
- Self-test as per IEC 62034
- 1 or 3 h rated duration
- Operating time selectable with plug (duration link)
- Compatible with all dimmable and non-dimmable constant current LED Drivers (see 5.3, LED Driver compatibility)
- 3-pole technology: 2-pole LED module changeover and delayed power switching for the LED Driver
- Automatic shutdown of output if LED load is out of range
- Constant power output
- Maximum light output for all LED modules
- Two-colour status display LED
- „Rest mode“ function
- Electronic multi-level charge system
- Intermittent charge for NiMH batteries (pulse charge)
- Deep discharge protection
- Short-circuit-proof battery connection
- Polarity reversal protection for battery
- Self-test:
 - Status of the battery
 - Status of the LED
 - Charge condition
 - Function test
 - Duration test

Batteries

- High-temperature cells
- NiCd or NiMH batteries
- D, Cs or LA cells
- 4-year design life
- 1-year guarantee
- For battery compatibility refer to chapter „Battery selection“



Standards, page 4

Wiring diagrams and installation examples, page 5



EM converterLED ST 200 V

SELFTEST series

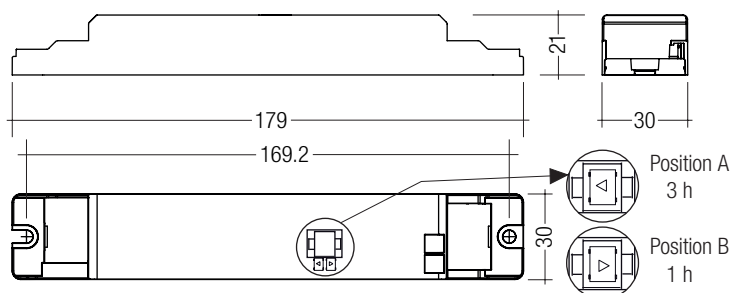

Note: LED Driver supplied with duration link in 3 hours position. Duration link must be set before battery and mains connection.

Technical data

Rated supply voltage	220 – 240 V
Mains frequency	50 / 60 Hz
LED module forward voltage range	50 – 200 V
Output current	see page 5
Time to light	< 0.25 s from detection of emergency event
Overvoltage protection	320 V (for 1 h)
U-OUT	250 V
Ambient temperature range t_a	-25 ... +55 °C
Max. casing temperature t_c	75 °C
Mains voltage changeover threshold	according to EN 60598-2-22
Type of protection	IP20
Rest mode max. number of emergency units	100
Rest mode max. wiring distance	1,000 m
Functional test	Weekly 5s test
Duration test	Yearly 1 h / 3 h test

Ordering data

Type	Article number	Rated duration	Number of cells	Packaging, carton	Packaging, pallet	Weight per pc.
EM converterLED ST 104 200V	89800310	1/3 h	4	10 pc(s).	1,600 pc(s).	0.08 kg
EM converterLED ST 105 200V	89800311	1/3 h	5	10 pc(s).	1,600 pc(s).	0.08 kg
EM converterLED ST 104 NiMH 200V	89800328	1/3 h	4	10 pc(s).	800 pc(s).	0.08 kg
EM converterLED ST 105 NiMH 200V	89800329	1/3 h	5	10 pc(s).	800 pc(s).	0.08 kg

Specific technical data

Type	Rated duration	Typ. λ (at 230 V, 50 Hz)	Typ. output power	Mains current in charging operation			Mains power in charging operation		
				Initial charge	Fast recharge	Trickle charge [®]	Initial charge	Fast recharge	Trickle charge [®]
EM converterLED ST 104 200V	1 h	0.45c	4.25 W	20 mA	25 mA	17 mA	3.0 W	3.0 W	1.7 W
	3 h	0.50c	4.25 W	27 mA	30 mA	20 mA	4.0 W	4.3 W	2.2 W
EM converterLED ST 105 200V	1 h	0.45c	5.40 W	20 mA	25 mA	17 mA	3.0 W	3.5 W	1.7 W
	3 h	0.50c	5.40 W	30 mA	35 mA	20 mA	4.5 W	4.8 W	2.5 W
EM converterLED ST 104 NiMH 200V	1 h	0.45c	4.25 W	27 mA	30 mA	24 / 22 mA	2.3 W	2.9 W	1.8 / 1.5 W
	3 h	0.50c	4.25 W	33 mA	35 mA	27 / 22 mA	3.9 W	4.2 W	2.3 / 1.5 W
EM converterLED ST 105 NiMH 200V	1 h	0.45c	5.40 W	28 mA	31 mA	24 / 23 mA	2.5 W	3.3 W	1.8 / 1.5 W
	3 h	0.50c	5.40 W	36 mA	38 mA	28 / 23 mA	4.4 W	4.8 W	2.5 / 1.5 W

[®] In case of 2 values: Intermittent charge is used. Value 1 is for 4 min. charge on / Value 2 is for 16 min. charge off

RoHS

ACCES-
SORIES

Test switch EM3

Product description

- For connection to the emergency lighting unit
- For checking the device function
- Plug connection



Ordering data

Type	Article number	Packaging, bag	Packaging, carton	Weight per pc.
Test switch EM 3	89899956	25 pc(s).	200 pc(s).	0.013 kg

ACCES-
SORIES

Status indication bi-colour LED

Product description

- Two-colour status display LED
- Green: system OK, red: fault
- Plug connection



Ordering data

Type	Article number	Packaging, bag	Packaging, carton	Weight per pc.
LED EM bi-colour, 1.0 m CON	89800273	25 pc(s).	200 pc(s).	0.015 kg
LED EM bi-colour, high brightness HO 1.0 m CON	89800275	25 pc(s).	200 pc(s).	0.015 kg
LED EM bi-colour, 0.6 m CON	89800474	25 pc(s).	200 pc(s).	0.005 kg
LED EM bi-colour, high brightness HO 0.6 m CON	89800475	25 pc(s).	200 pc(s).	0.005 kg
LED EM bi-colour, 0.3 m CON	89800274	25 pc(s).	200 pc(s).	0.005 kg
LED EM bi-colour, high brightness HO 0.3 m CON	89800276	25 pc(s).	200 pc(s).	0.005 kg

1. Standards

- according to EN 50172
- according to EN 60598-2-22
- EN 61347-1
- EN 61347-2-13
- EN 61347-2-7
- EN 55015
- EN 61000-3-2
- EN 61000-3-3
- EN 61547
- EN 60068-2-64
- EN 60068-2-29
- EN 60068-2-30
- EN 62384
- EN 62034

1.1 Glow-wire test

according to EN 61347-1 with increased temperature of 850 °C passed.

1.2 Isolation and electric strength testing of luminaires

Electronic LED-Drivers can be damaged by high voltage. This has to be considered during the routine testing of the luminaires in production.

According to IEC 60598-1 Annex Q (informative only!) or ENEC 303-Annex A, each luminaire should be submitted to an isolation test with 500 V_{DC} for 1 second. This test voltage should be connected between the interconnected phase and neutral terminals and the earth terminal. The isolation resistance must be at least 2 M Ω .

As an alternative, IEC 60598-1 Annex Q describes a test of the electrical strength with 1,500 V_{AC} (or 1,414 x 1,500 V_{DC}). To avoid damage to the electronic devices this test **must not be conducted**.

2. Thermal details and life-time

2.1 Life-time

Average life-time 50,000 hours under rated conditions with a failure rate of less than 10 %. Average failure rate of 0.2 % per 1000 operating hours.

3. Installation / Wiring

3.1 Wiring diagram

One or more LED modules with a total forward voltage of 50 to 200 V can be connected to the EM converterLED 200V module. These LED module(s), marked with "Emergency" are operated in emergency mode from the associated battery. In normal mains mode all LED modules are operated by the mains LED Driver.

EM converterLED SELFTEST with one LED module for non-maintained emergency operation

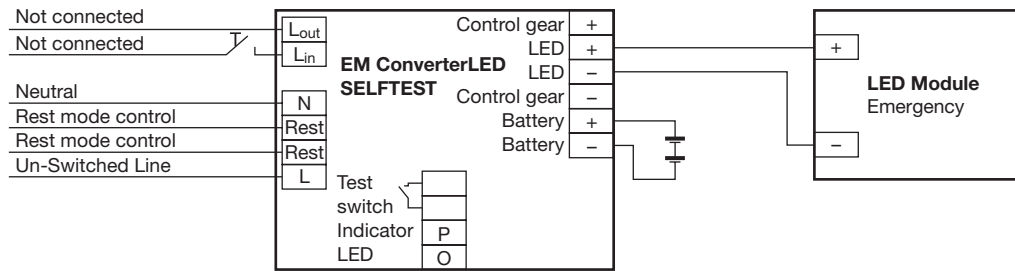

EM converterLED SELFTEST with a standard LED Driver and one LED module for mains and emergency operation

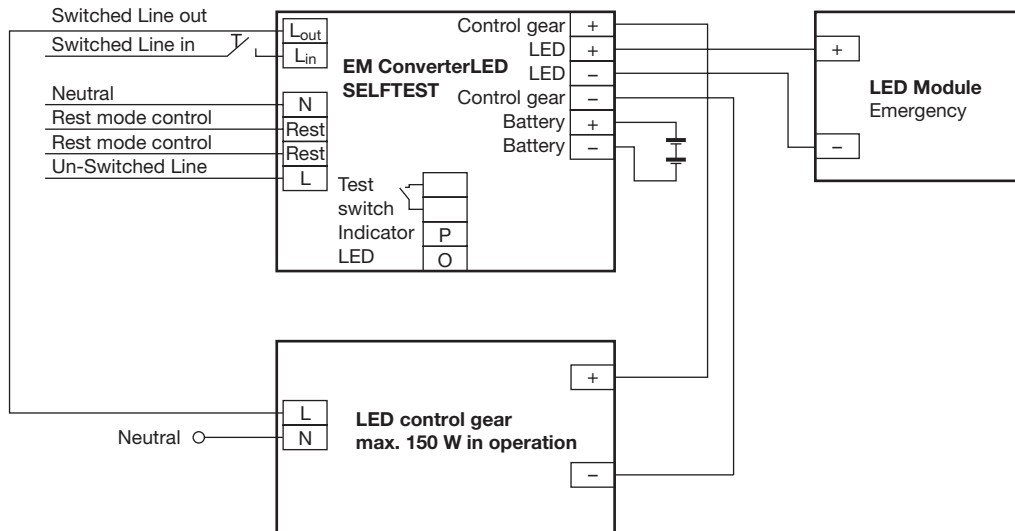

EM converterLED SELFTEST with a standard LED Driver and series operation of LED modules

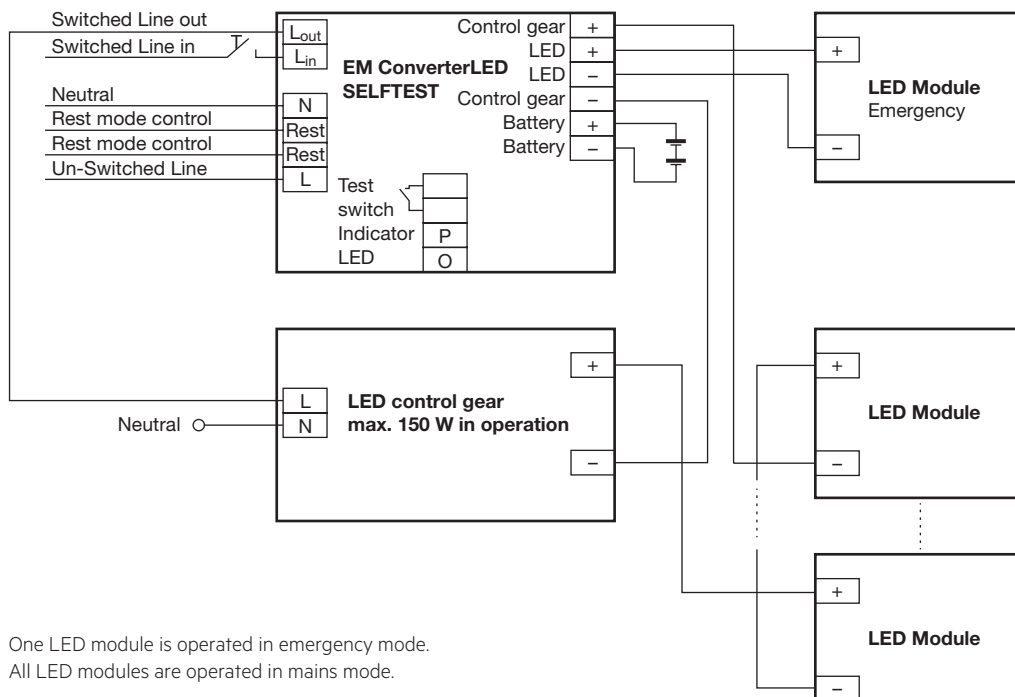

One LED module is operated in emergency mode.
All LED modules are operated in mains mode.

EM converterLED SELFTEST with a standard LED Driver and series operation of LED modules

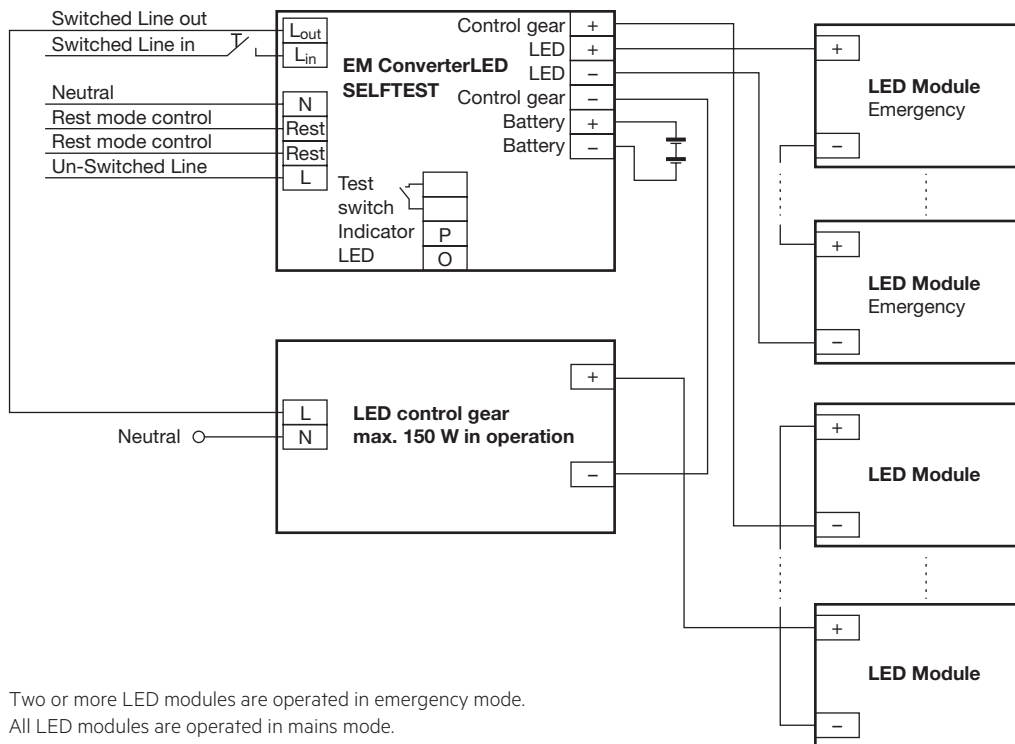

EM converterLED SELFTEST with a standard LED Driver and parallel operation of LED modules

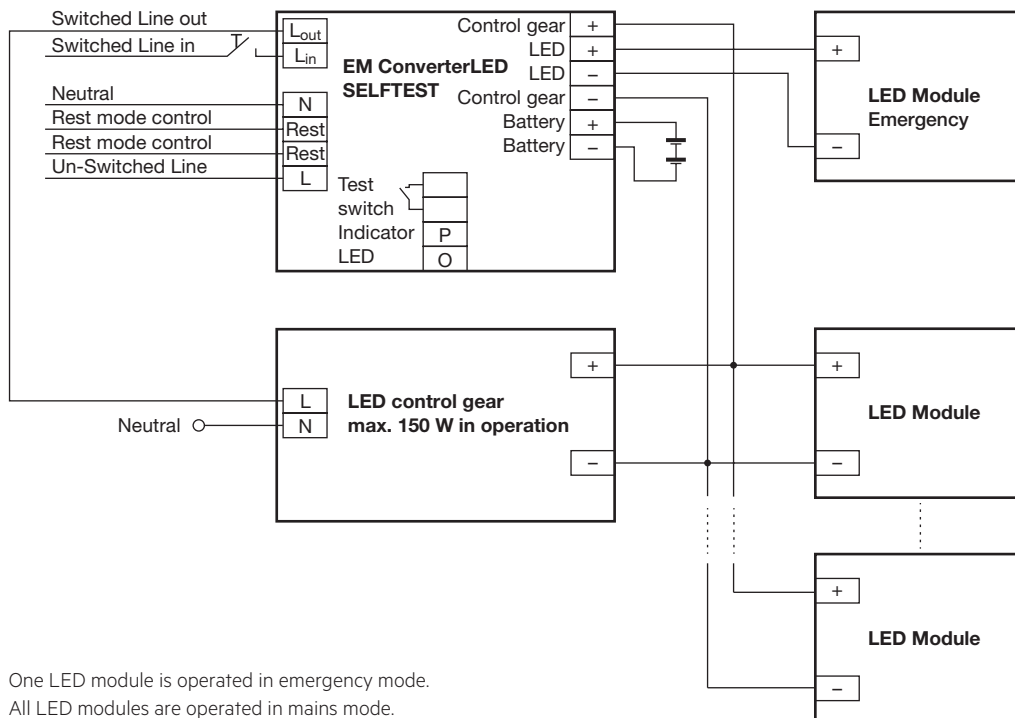

EM converterLED SELFTEST with a standard LED Driver and parallel operation of LED modules

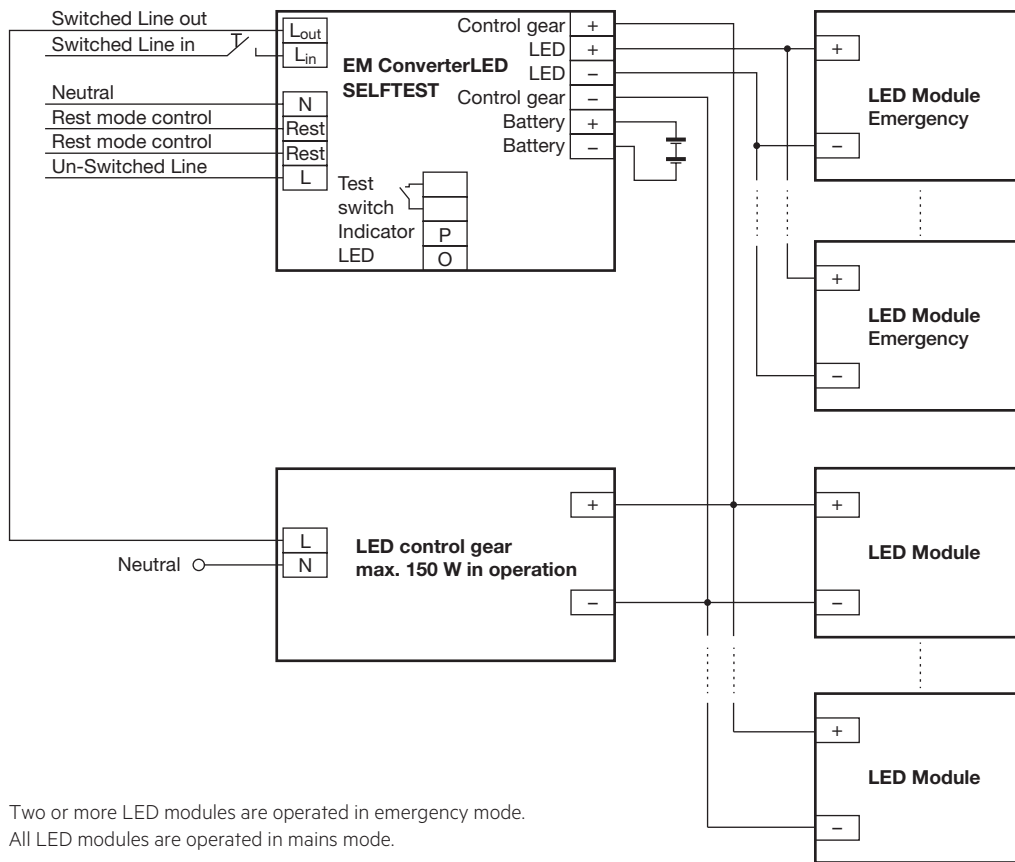

Two or more LED modules are operated in emergency mode.
All LED modules are operated in mains mode.

3.2 Wiring type and cross section

Solid wire with a cross section of 0.5 – 1.5 mm². Strip 8 – 9 mm of insulation from the cables to ensure perfect operation of terminals.

Wiring: LED module/LED Driver/supply

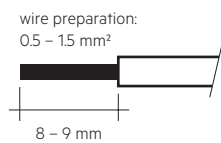

3.3 Loose wiring

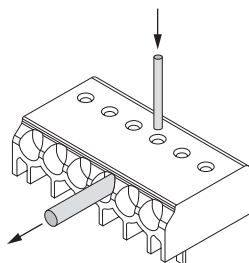

Loosen wire through twisting and pulling or using a Ø 1 mm release tool

3.4 Wiring guidelines

- The indicator LED and test switch terminals are classified as SELV (output voltage < 60 V DC). Keep the wiring of the input terminals separated from the wiring of the SELV equivalent terminals or consider special wiring (double insulation, 6 mm creepage and clearance) when these connections should be kept SELV.
- The output to the LED is DC but has high frequency content, which should be considered for good EMC compliance.
- LED leads should be separated from the mains and DALI connections and wiring for good EMC performance.
- Maximum lead length on the LED terminals is 3 m. For a good EMC performance keep the LED wiring as short as possible.
- Maximum lead length for the Test switch and Indicator LED connection is 1 m. The test switch and Indicator LED wiring should be separated from the LED leads to prevent noise coupling.
- Battery leads are specified with 0.5 mm cross section and a length of 1.3 m
- DALI terminals are mains proof

To ensure that a luminaire containing LED emergency units complies with EN 55015 for radio frequency conducted interference in both normal and emergency mode it is essential to follow good practice in the wiring layout.

Within the luminaire the switched and unswitched 50 Hz supply wiring must be routed as short as possible and be kept as far away as possible from the LED leads. Through wiring may affect the emc performance of the luminaire.

The length of LED leads to the LED module must not be exceeded. Note that the length of the EM converterLED leads to the LED module is added to the length of the leads from the LED Driver to the EM converterLED module when considering the max. permitted lead length of the LED Driver.

3.5 Maximum lead length

LED 3 m^①
 Status indication LED 1 m
 Batteries 1.3 m

^① Note: The length of LED leads to the LED module must not be exceeded. Note that the length of the EM converterLED leads is added to the length of the leads from the LED Driver to the EM converterLED module when considering max. permitted lead length of the LED Driver. Leads should always be kept as short as possible.

3.6 Use of different phases

The use of different phases for switched line and unswitched line is allowed. When using different phases, the unswitched line must fail if the switched line fails. This is required to assure correct switching into emergency mode. It can be realised with a relay.

3.7 EM FLT1 filter

When the EM converterLED is used in a remote application, where the lamp leads and LED indicator leads are routed together in close proximity, it is possible to have electrical interference picked up in the indicator leads.

Under certain conditions this interference can cause a lock-up of the EM converterLED micro-controller.

To overcome this problem in such applications it is necessary to fit the filter EM FLT1 between the indicator LED and the EM converterLED unit. To be effective the filter must be connected close to the EM converterLED module.

For further information please contact Tridonic.

Technical data:

Push wire terminals 0.5–1.5 mm² solid conductor

Ordering data

Type	Article number	Packaging, carton	Packaging, pallet	Weight per pcs.
EM FLT1	89899942	50 pieces	1,000 pieces	0.022 kg

EM FLT1 filter

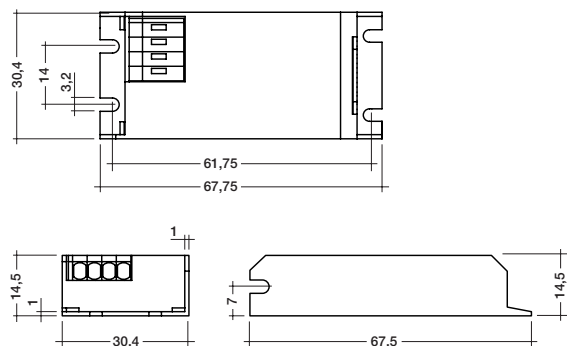

Circuit diagram with EM FLT1 filter

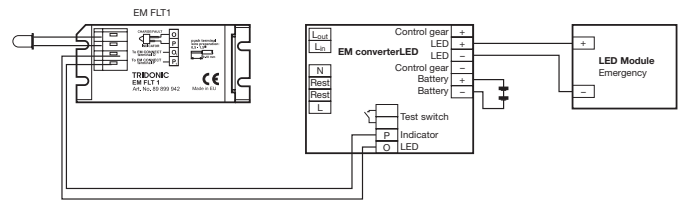

4. Mechanical values

4.1 Housing properties

Casing manufactured from polycarbonate.

4.2 Mechanical data accessories

LED status indicator

- Bi-colour
- Mounting hole 6.5 mm dia
- Lead length 0.3 m / 1.0 m
- Insulation rating: 90 °C
- Plug connection

Test switch

- Mounting hole 7.0 mm dia
- Lead length 0.55 m
- Plug connection

Battery leads

- Quantity: 1 red and 1 black
- Length: 1.3 m
- Wire type: 0.5 mm² solid conductor
- Insulation rating: 90 °C

Battery end termination

Push on 4.8 mm receptacle to suit battery spade fitted with insulating cover

Module end termination

8.0 mm stripped insulation

Two-piece batteries are supplied with a 200 mm lead with 4.8 mm receptacle at each end and insulating covers to connect the separate sticks together.

5. Electrical values

5.1 Maximum loading of automatic circuit breakers

Automatic circuit breaker type	B10	B13	B16	B20	C10	C13	C16	C20	Inrush current	
Installation \varnothing	1.5 mm ²	1.5 mm ²	1.5 mm ²	2.5 mm ²	1.5 mm ²	1.5 mm ²	1.5 mm ²	2.5 mm ²	I_{max}	time
EM converterLED 104 ST 200V	90	130	130	130	180	260	260	260	10 A	120 μ s
EM converterLED 105 ST 200V	90	130	130	130	180	260	260	260	10 A	120 μ s

5.2 Typ. LED current/voltage characteristics

The LED current in emergency mode is automatically adjusted by the EM converterLED module based on the total forward voltage of the LED modules connected and the associated battery.

EM converterLED ST 104 200V / EM converterLED ST 104 NiMH 200V

Article number: 89800310 / 89800328

4.8 V battery voltage

850 – 960 mA battery discharge current (tolerance)

EM converterLED ST 105 200V / EM converterLED ST 105 NiMH 200V

Article number: 89800311 / 89800329

6.0 V battery voltage

850 – 960 mA battery discharge current (tolerance)

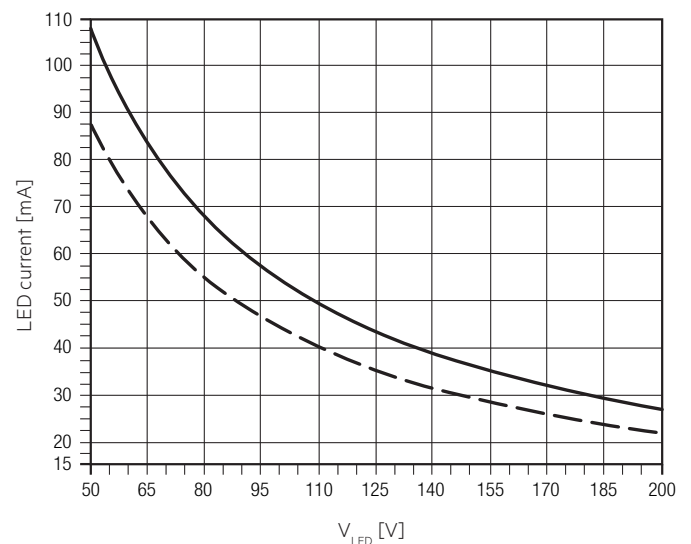
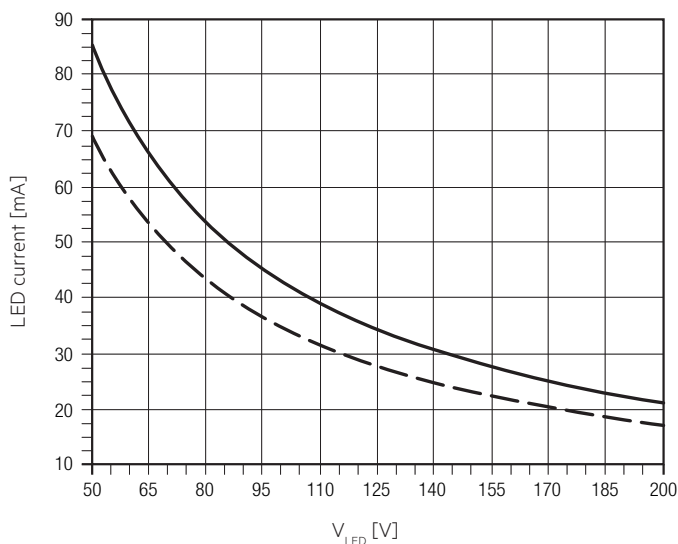

LED peak current at start in emergency mode – 4 cells

Voltage	Inrush current	Duration
49.5 V	137 mA	23.8 ms
62.2 V	121 mA	17.9 ms
74.9 V	107 mA	13.8 ms
85.0 V	97 mA	11.7 ms
100.0 V	86 mA	9.9 ms
110.3 V	81 mA	8.9 ms
122.8 V	76 mA	7.9 ms
135.3 V	70 mA	6.8 ms
145.4 V	66 mA	6.0 ms
155.3 V	62 mA	5.6 ms
170.3 V	58 mA	4.5 ms
180.3 V	53 mA	3.2 ms
190.0 V	51 mA	2.5 ms
200.0 V	43 mA	2.3 ms

LED peak current at start in emergency mode – 5 cells

Voltage	Inrush current	Duration
49.8 V	169 mA	30.7 ms
62.6 V	142 mA	19.7 ms
75.3 V	129 mA	14.7 ms
85.5 V	122 mA	12.8 ms
100.8 V	111 mA	10.8 ms
110.9 V	104 mA	9.4 ms
123.4 V	98 mA	7.9 ms
136.0 V	93 mA	7.4 ms
146.0 V	89 mA	6.2 ms
156.0 V	84 mA	5.7 ms
171.1 V	80 mA	4.4 ms
181.1 V	76 mA	4.1 ms
191.1 V	73 mA	3.5 ms
201.0 V	71 mA	3.2 ms

Note: LED peak current measured at the max. battery discharge current and a max. battery voltage of 6 V (4 cells) or 7.5 V (5 cells).

- — — LED current at nominal battery voltage and min. battery discharge current
- — — LED current at nominal battery voltage and max. battery discharge current



5.3 LED-Driver compatibility

The EM converterLED emergency unit use 3 pole technology and is compatible with most LED Driver on the market, however it is important to check that the rating of the LED Driver does not exceed the values specified below:

- The max. allowed output current rating of the associated LED Driver is 2.4 A peak (current rating of switching relays of EM converterLED)
- The max. allowed inrush current rating of the associated LED Driver is 60 A peak for 1 ms or 84 A for 255 μ s (inrush current rating of switching relay of EM converterLED)
- The max. allowed output voltage of the associated LED Driver applied to the EM converterLED output is 450V (voltage withstand between adjacent contact of the single switching relay of the EM converterLED)
- The max. allowed LED load of the associated LED Driver is 150 W in operation. The load must be an LED module.

6. Functions

6.1 Duration link selection

Duration	Link position
3 hr	 Position A
1 hr	 Position B

Module supplied with duration link in 3 hours position (position A).

The position of the link will only be read on first power up. If it is changed afterwards both the battery and mains supply must be disconnected for 10 seconds to enable the EM converterLED to read the new link position on reconnection of the battery and mains. It will lead to a false battery failure indication if the link is changed after installation without this reset.

6.2 Status indication

System status is indicated by a bi-colour LED.

LED indication	Status	Comment
Permanent green	System OK	AC mode
Fast flashing green (0,1 sec on – 0,1 sec off)	Function test underway	
Slow flashing green (1 sec on – 1 sec off)	Duration test underway	
Red LED on	Load failure	Open circuit / Short circuit / LED failure
Slow flashing red (1 sec on – 1 sec off)	Battery failure	Battery failed the duration test or function test / Battery is defect or deep discharged/ Incorrect battery voltage
Fast flashing red (0,1 sec on – 0,1 sec off)	Charging failure	Incorrect charging current
Double pulsing green	Inhibit mode	Switching into inhibit mode via controller
Green and red off	DC mode	Battery operation (emergency mode)

6.3 Commissioning

After installation of the luminaire and initial connection of the mains supply and battery supply to the EM converterLED ST the unit will commence charging the batteries for 20 hours (initial charge). The 20 hours recharge occurs also if a new battery is connected or the module exits the rest mode condition.

The following automatic commissioning duration test is only performed when a battery is replaced and fully charged (after 20 hours).

6.4 Testing

Commissioning test

A full commissioning test is carried out automatically after permanent connection of the supply for 5 days. The easy commissioning feature will set the initial test day and time to ensure random testing of units.

Functional test

Functional tests are carried out for 5 seconds on a weekly basis under the control of the Micro controller. Initiation and timing of these tests is set during the commissioning of the luminaire.

Duration test

A full duration test is carried out yearly to check the capacity of the batteries.

For a full description of commissioning and test features please refer to application notes.

Test switch

An optional test switch can be wired to each EM converterLED ST. This can be used to:

- Initiate a 5 seconds function test: press 200 ms < T < 1 s
- Execute function test as long as switch pressed: press > 1 s
- Reset selftest timer (adjust local timing): press > 10 s

Timer reset functionality

The timer for function and duration test can be set to a particular time of the day by either pressing the test switch for longer than 10 seconds or cycling the unswitched line supply 5 times within 1 minute. The timer adjustment will enable the test start time to be defined manually at time in day when the timer was reset. It will also disable the adaptive test algorithm thereby forcing the unit to perform the test at the same time rather than it being defined by the adaptive algorithm. This function will only work provided the interval time is greater than zero (automatic test mode enabled). The delay timer value set when the unit was commissioned will be reloaded in order to randomise the tests between adjacent units.

Rest mode

Rest mode can be initiated by applying a short pulse of between 9.5 V_{DC} and 22.5 V_{DC} in amplitude for a period of between 150 ms and 1.0 s. This should be applied to terminals marked Rest after the mains supply has been disconnected and whilst the module is in emergency operation. Terminals are not sensitive to polarity.

After a mains reset the EM converterLED ST exits the rest mode. The EM converterLED ST supports the re-light function.

Pulse/Mode	Standby	Emergency	Rest
150 – 1,000 ms	Inhibit	Rest	–
1,001 – 2,000 ms	Cancel inhibit	–	re-light

7. Battery data

7.1 Battery selection

EM converterLED SELFTEST, 1 / 3 h

			Type	EM converterLED ST 104 200V	EM converterLED ST 105 200V	EM converterLED ST 104 NiMH 200V	EM converterLED ST 105 NiMH 200V				
			Article no.	89800310		89800311		89800328		89800329	
			Cells	4 cells		5 cells		4 cells		5 cells	
			Duration	1 h 3 h		1 h 3 h		1 h 3 h		1 h 3 h	
Technology and capacity	Design	Number of cells	Type	Article no.	Assignable batteries						
NiCd 1.6 Ah Cs cells	stick	1 x 4	Accu-NiCd C 4A	89899692	•						
	stick	1 x 5	Accu-NiCd C 5A	89899695		•					
	stick + stick	2 + 2	Accu-NiCd C 4C	89899694	•						
	stick + stick	3 + 2	Accu-NiCd C 5C	89899697		•					
	side by side	4 x 1	Accu-NiCd C 4B	89899693	•						
	side by side	5 x 1	Accu-NiCd C 5B	89899696		•					
NiCd 4 Ah D cells	stick	1 x 4	Accu-NiCd 4A 55	89800089		•					
	stick	1 x 5	Accu-NiCd 5A	89895973			•				
	stick + stick	2 + 2	Accu-NiCd 4C	89895978		•					
	stick + stick	3 + 2	Accu-NiCd 5C 55	89800090			•				
	side by side	4 x 1	Accu-NiCd 4B 55	89800385		•					
NiMH 2 Ah Cs cells	stick	1 x 4	Accu-NiMH C 4A	89899700	•			•			
	stick	1 x 5	Accu-NiMH C 5A	89899703		•				•	
	side by side	5 x 1	Accu-NiMH C 5B	89899704		•				•	
NiMH 4 Ah LA cells	stick	1 x 4	Accu-NiMH 4Ah 4A CON	89800442		•			•		
	stick + stick	2 + 2	Accu-NiMH 4Ah 4C CON	89800438		•				•	
	stick + stick	3 + 2	Accu-NiMH 4Ah 5C CON	89800439			•				•

7.2 Battery charge / discharge data

EM converterLED SELFTEST, 1 / 3 h

		EM converterLED ST 104 200V		EM converterLED ST 105 200V		EM converterLED ST 104 NiMH 200V		EM converterLED ST 105 NiMH 200V			
		Article no.		89800310		89800311		89800328		89800329	
		Cells		4 cells		5 cells		4 cells		5 cells	
		Duration		1 h 3 h		1 h 3 h		1 h 3 h		1 h 3 h	
Battery charge time	Initial charge	20 h									
	Fast recharge	10 h	15 h [®]	10 h	15 h [®]	10 h	15 h [®]	10 h	15 h [®]	10 h	15 h [®]
	Trickle charge	continuously									
Charge current	Initial charge	130 mA	300 mA	130 mA	300 mA	130 mA	300 mA	130 mA	300 mA	130 mA	300 mA
	Fast recharge	210 mA	330 mA	210 mA	330 mA	210 mA	330 mA	210 mA	330 mA	210 mA	330 mA
	Trickle charge	50 mA	130 mA	50 mA	130 mA	130 mA / 4 min. 0 mA / 16 min.	200 mA / 4 min. 0 mA / 16 min.	130 mA / 4 min. 0 mA / 16 min.	200 mA / 4 min. 0 mA / 16 min.	130 mA / 4 min. 0 mA / 16 min.	200 mA / 4 min. 0 mA / 16 min.
Discharge current		850 – 960 mA	850 – 960 mA	850 – 960 mA	850 – 960 mA	850 – 960 mA	850 – 960 mA	850 – 960 mA	850 – 960 mA	850 – 960 mA	850 – 960 mA

[®] 2 h emergency operation can be achieved after 12 h of charging.

7.3 Accu-NiCd**1.6 Ah**

Battery voltage/cell	1.2 V
Cell type	Cs
Case temperature range to ensure 4 years design life	+5 °C to +50 °C
Max. short term temperature (reduced life-time)	70 °C
Max. number discharge cycles	4 cycles per year plus 4 cycles during comissioning
Max. storage time	6 months

4.2 / 4.5 Ah

Battery voltage/cell	1.2 V
Cell type	D
Case temperature range to ensure 4 years design life	5 °C to +55 °C
Max. short term temperature (reduced life-time)	70 °C
Max. number discharge cycles	4 cycles per year plus 4 cycles during comissioning
Max. storage time	6 months

7.4 Accu-NiMh**2.0 Ah**

Battery voltage/cell	1.2 V
Cell type	Cs
Case temperature range to ensure 4 years design life	+5 °C to +55 °C
Max. short term temperature (reduced life-time)	70 °C
Max. number discharge cycles	4 cycles per year plus 30 cycles during comissioning
Max. storage time	6 months

4.0 Ah

Battery voltage/cell	1.2 V
Cell type	LA
Case temperature range to ensure 4 years design life	
When used with EM converterLED ST xx 200V	+5 °C to +45 °C
When used with EM converterLED ST xx NiMH 200V	+5 °C to +50 °C
Max. short term temperature (reduced life-time)	70 °C
Max. number discharge cycles	4 cycles per year plus 30 cycles during comissioning
Max. storage time	6 months

7.5 Wiring batteries

Connection method: 4.8 x 0.5 mm spade tag welded to end of cell.

For stick packs this connection is accessible after the battery caps have been fitted.

To inhibit inverter operation disconnect the batteries by removing the connector from the battery spade tag.

For further information refer to corresponding battery datasheet.

7.6 Storage, installation and commissioning

Relevant information about storage conditions, installation and commissioning are provided in the battery datasheets.

8. Miscellaneous**8.1 Additional information**

Additional technical information at www.tridonic.com → Technical Data

Guarantee conditions at www.tridonic.com → Services

Life-time declarations are informative and represent no warranty claim.
No warranty if device was opened.