

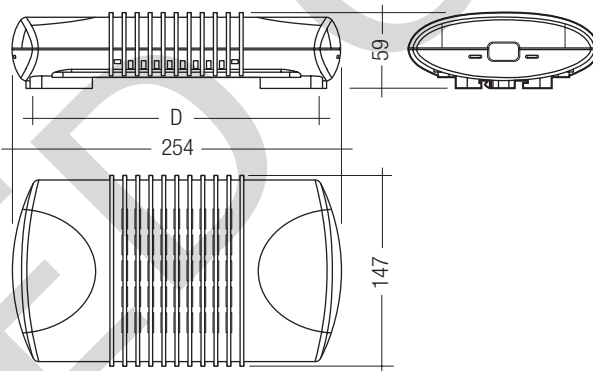

TE-DC 2 F101, 100 – 300 VA 230 – 240/12 V 0/50/60 Hz
Fixed output

Product description

- Independent device with integrated cable clamp and terminal cover
- Constant output voltage
- For emergency lighting systems as per EN 50172
- Short-circuit shutdown feature with automatic restart
- With soft start
- Overtemperature and overload protection by reducing power and automatic restart
- Quiet operation
- Suitable for cable lengths up to 20 m
- Double assignment of the terminal possible
- Practical individual packaging with assembly instructions
- Rapid installation of the cable clamp, no tools required
- Not suitable for operation with MR16 LED bulbs



Technical data

Protection class	II
Mains frequency	0 / 50 / 60 Hz
Efficiency	> 90 %
λ	0.99
Power circuitry	digital

Ordering data

Lamp wattage	Dimensions LxWxH	Distance between mounting holes (D)	Dimming	Type	Article number
100–300 VA	254 x 147 x 59 mm	218–226 mm	not provided (fixed output)	TE-DC 2 0300 F101 white	86458505
100–300 VA	254 x 147 x 59 mm	218–226 mm	not provided (fixed output)	TE-DC 2 0300 F101 grey	86458503

Packaging: 10 pieces/carton, 120 pieces/pallet

Specific technical data

Type	Rated supply voltage AC	Rated supply voltage DC	Rated current (at 230 V 50 Hz)	Secondary voltage ^o	DC lamp output	Ambient temperature t_a	Max. casing temperature	Current monitor	Soft-start	Weight	Output terminal
TE-DC 2 0300 F101	230 – 240 V	230 – 240 V	1.45 A	11.9 V	70 %	-20 ... +35 °C	100 °C	yes	yes	0.8 kg	2-pin, screw terminal

^o Constant output voltage.

Data secondary terminal

Possible Wiring

Clamping area	0.33 – 16.00 mm ²
Single wire/H05(07) V-U	0.5 – 16.00 mm ²
braided wire/H05(07) V-K	0.5 – 10.00 mm ²
braided wire/DIN 46228-1	2.5 – 10.00 mm ²
braided wire/DIN46228-4	2.5 – 10.00 mm ²
plug gage/EN 60999	Ø 5.3 (B6)



Definiton plug gauge

Conductor cross-section		Plug gauge					
		Form A			Form B		
Flexible conductor	Rigid conductor (solid or stranded)	Designation	Diameter a	Width b	Designation	Diameter a	Permissible deviation for a and b
1.5 mm ²	1.5 mm ²	A1	2.4 mm	1.5 mm	B1	1.9 mm	0 – 0.05 mm
2.5 mm ²	2.5 mm ²	A2	2.8 mm	2.0 mm	B2	2.4 mm	
2.5 mm ²	4 mm ²	A3	2.8 mm	2.4 mm	B3	2.7 mm	
4 mm ²	6 mm ²	A4	3.6 mm	3.1 mm	B4	3.5 mm	0 – 0.06 mm
6 mm ²	10 mm ²	A5	4.3 mm	4.0 mm	B5	4.4 mm	
10 mm ²	16 mm ²	A6	5.4 mm	5.1 mm	B6	5.3 mm	

Wiring diagram

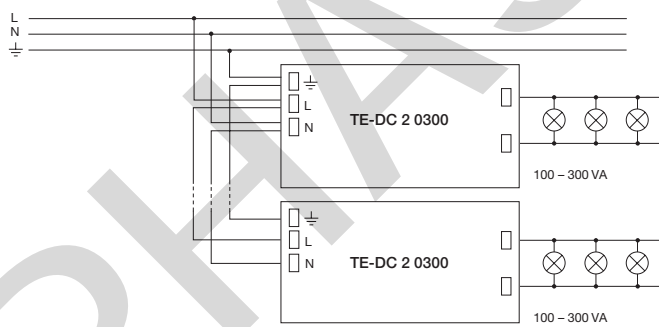

Minimum spacing (mm)

